

## INSTRUCTION SHEET FOR BACKUP ALARMS

### SAFETY MESSAGE TO INSTALLERS OF BACKUP ALARMS



People's lives depend on your safe installation of our products in conformance with our instructions. It is necessary to read, understand and follow all instructions shipped with the products. In addition, listed below are some other important safety instructions and precautions you should follow.

- To properly install a backup alarm: you must have a good understanding of truck and heavy equipment electrical procedures and systems, along with proficiency in the installation and use of safety warning equipment.
- When drilling into a vehicle structure, be sure that both sides of the surface are clear of anything that could be damaged.
- Locate Backup Alarm so it will operate safely under all conditions. The location must provide protection from impact and adverse weather conditions while allowing unobstructed sound projection to the target hazard area.
- All effective Backup Alarms produce loud sounds which may cause, in certain situations, permanent hearing loss. You should take appropriate precautions and follow your employer's hearing conservation program and safety guidelines for instructions as to whether you should wear hearing protection.
- Ensure that the vehicle's supply voltage is within the voltage rating specified on the Backup Alarm.
- You should frequently inspect the Backup Alarm system to ensure that it is operating properly and that it is securely attached to the vehicle.
- File a copy of these instructions in a safe place and refer to them when maintaining and/or reinstalling the product. Pass these instructions on to the operator of the backup alarm system.

Failure to follow all safety precautions and instructions may result in property damage, serious injury or death to you or others you are seeking to protect.

### I. GENERAL.

These Backup Alarms are lightweight, low current, piezo-electric, solid-state audible warning devices. They can generate a pulsed (beeping) warning tone. Reverse polarity protection is provided. The housing is environmentally sealed against moisture, dust, and corrosion. All units are supplied with a rubber mounting grommet.

### II. SPECIFICATIONS.

Operating Voltage	9-28VDC
Operating Current	0.15 A @ 12VDC
Pulse Frequency	80 Beeps per minute $\pm 20$
Frequency	2400 Hz $\pm 400$ Hz
Temperature Range	-40° F to 165° F (-40° C to +74° C)

### III. KIT CONTENTS LIST.

Qty.	Description
1	Grommet, Rubber
2	Screw, Pan Hd., 6-32 x 1/4"
2	Lockwasher, Int. Tooth, #6
1	Label, Warning
2	Connector, Ring, 18-20 Gauge

### IV. INSTALLATION.



This alarm is designed to concentrate its audible alarm in the target hazard area. For proper warning signal coverage, the alarm should be mounted approximately 4 ft. above ground level with the unit's sound ports facing the target hazard area. There should be no obstructions around or blocking the sound ports of the unit.

Do not mount the alarm with the sound ports facing upwards where it can become buried, submerged or clogged with mud, water and other debris. A clogged alarm will be rendered ineffective and will produce little or no sound output. Always be sure that the alarm's sound ports are facing the area you are trying to warn, the ports are not clogged and that the alarm is functioning properly before using the vehicle.

Select a mounting location at the rear of the vehicle that will provide protection from impact and adverse weather conditions while allowing unobstructed sound projection to the target hazard area.

It is recommended that the mounting location be outside of the path of any possible road debris that may be kicked up while the vehicle is in operation. Provide a stone shield or mount in a location that will protect this alarm from debris if needed.

The supplied rubber grommet provides mounting flexibility and allows installation in a variety of locations. Ensure that the sound openings are positioned to allow unobstructed sound projection to the target hazard area.

A. *Grommet Mounting.*



Before drilling or cutting holes in ANY part of a vehicle, be sure that both sides of the mounting surface are clear of parts that could be damaged; such as brake lines, electrical wiring, or other vital parts.

Cut a 3" round opening for the alarm at the desired location. Orient the grommet with the lettering upright and insert it into the opening for the alarm. Use liquid soap as a lubricant if needed.

B. *Electrical (see figure 1).*

1. Terminate one end of a user-supplied red (or white) 18 gauge wire with a supplied #6 ring terminal. Terminate one end of a user-supplied black 18 gauge wire with the other #6 ring terminal.

2. Using a #6-32 x 1/4" screw and #6 lockwasher, connect the red (or white) wire to the "+" terminal on the alarm. Using a #6-32 x 1/4" screw and #6 lockwasher, connect the black wire to the "-" terminal on the alarm.

3. Route the other end of the red (or white) wire through the rubber grommet to the vehicle's backup light circuit, or to an independent actuating switch. **DO NOT** connect the red (or white) wire to the backup-light circuit, or to the independent actuating switch, at this time.

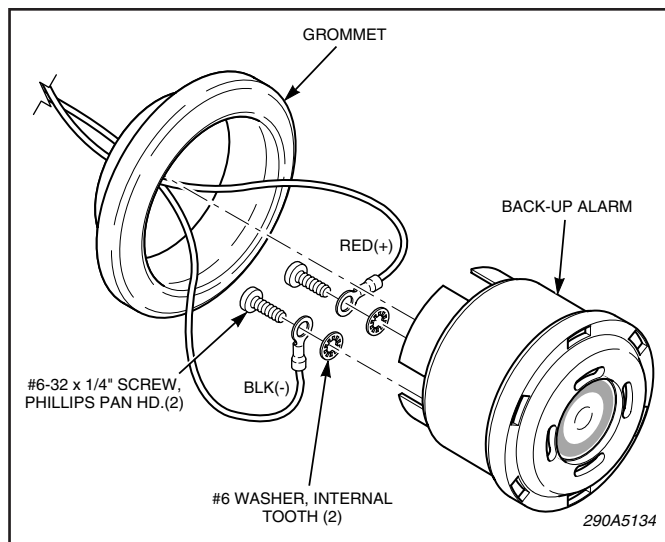

Figure 1.



**Improper grounding could cause the alarm to function improperly and result in death or serious injury to those who rely on this device for safety. The ground connection (-) must be attached to a solid metal body or chassis part that will provide a dependable ground path for as long as the device is to be used.**

4. Connect the other end of the black wire through the rubber grommet to a known good chassis ground.

C. *Final Installation and Testing.*

1. See figure 2. Connect the red (or white) wire to the vehicle's backup light circuit, or to an independent actuating switch.

2. Install the WARNING label in a location clearly visible to the operator at all times.

3. See figure 3. Orient the backup alarm with the lettering upright and push it into the grommet until completely seated. Use liquid soap as a lubricant if needed.

4. Test the backup alarm for proper operation.

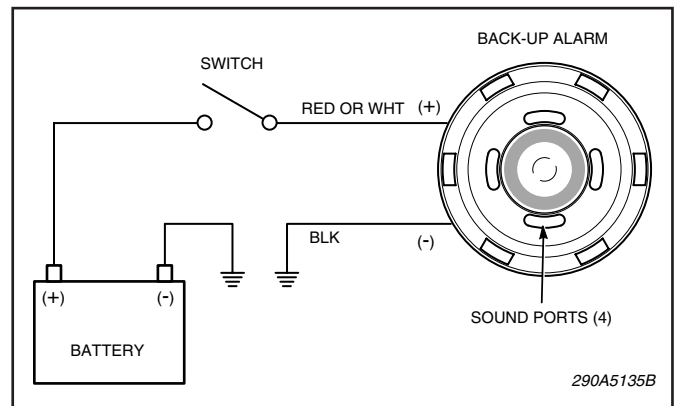

Figure 2.

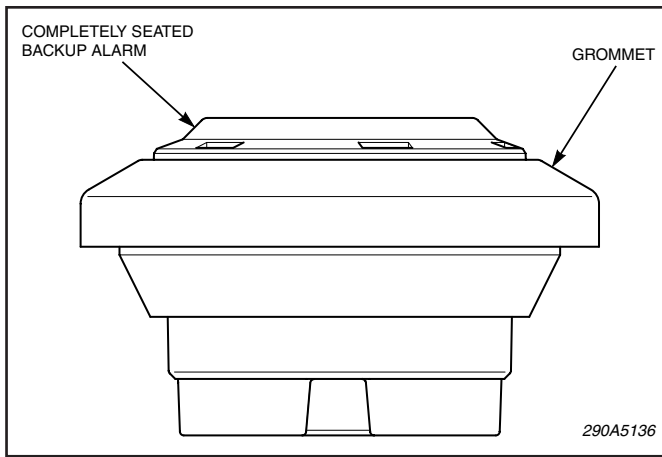

Figure 3.

## SAFETY MESSAGE TO OPERATORS OF BACKUP ALARMS



- Do not operate the vehicle if the alarm is inoperative; it could jeopardize the safety or lives of those who depend on the alarm signal for safety.
- All effective Backup Alarms produce loud sounds which may cause, in certain situations, permanent hearing loss. You should follow your employer's hearing conservation program and safety guidelines for instructions as to whether you should wear hearing protection.
- Your hearing and the hearing of others, in or close to your vehicle, could be damaged by loud sounds. This can occur from short exposures to very loud sounds, or from longer exposures to moderately loud sounds. For hearing conservation guidance, refer to federal, state, or local recommendations. OSHA Standard 1910.95 offers guidance on "Permissible Noise Exposure."
- Optimum sound propagation will be reduced if Backup Alarm becomes clogged with a foreign substance such as mud or snow. While cleaning, ensure that foreign material is not packed into the sound ports.
- Although your warning system is operating properly, it may not alert everyone. People may not hear, see, or heed your warning signal. You must recognize this fact and continue to operate your vehicle cautiously.
- Testing the Backup Alarm should be listed on the daily maintenance report. The units on operating vehicles must be tested each day prior to the vehicles' operation. Results of this test must be recorded in the maintenance file.
- Notify your supervisor that people operating this equipment **MUST** check for proper operation at the beginning of every shift.
- It is important that you fully understand how to safely operate this warning system before use.