

# 9K, 10K, and 13G General Duty Two-Piece Hub Group

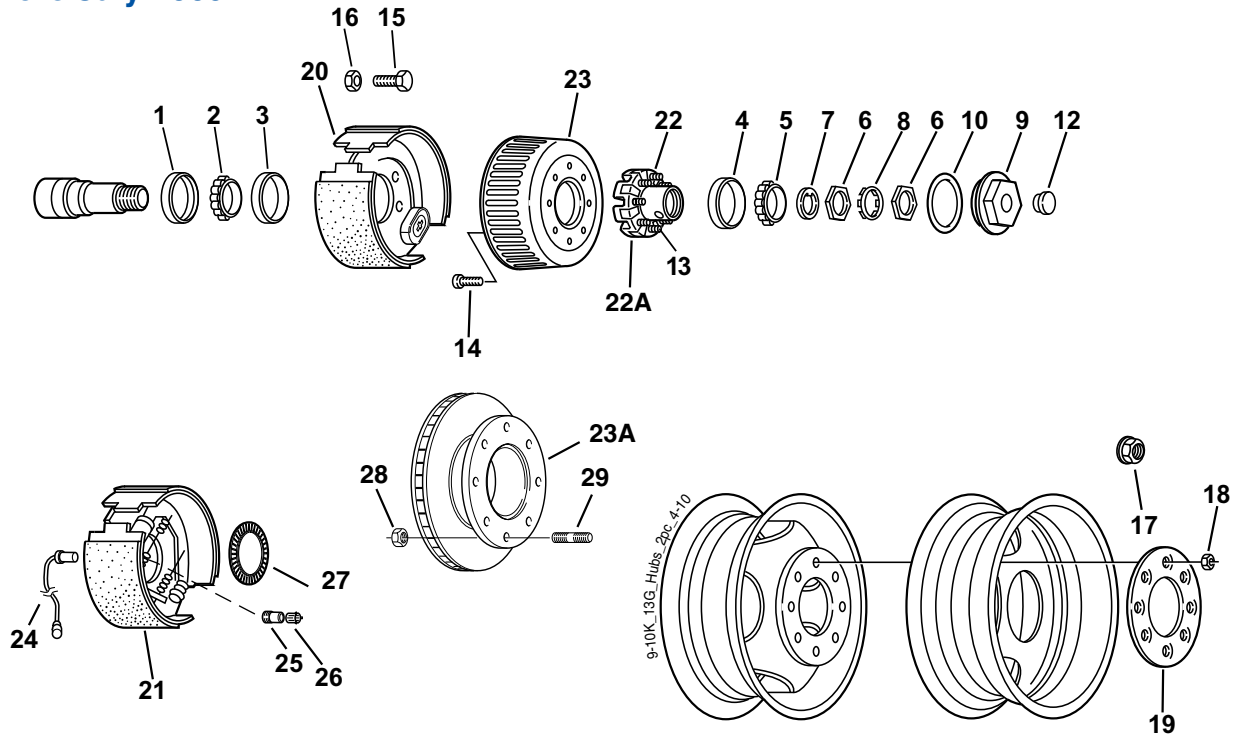

Before July 2009



## Standard Oil Lube Parts

Item	Part No.	Description
1	010-051-00	Oil Seal
2	031-019-02	387A Inner Bearing Cone
3	031-019-01	382A Inner Bearing Cup
4	031-030-01	25520 Outer Bearing Cup
5	031-030-02	25580 Outer Bearing Cone
6	006-096-00	Spindle Nut (2)
7	005-070-00	Spindle Washer
8	005-071-00	Tang Washer
9	021-036-00	Oil Cap
10	010-050-00	'O' Ring
12	046-032-00	Oil Cap Plug
13	007-115-00	5/8-18 Wheel Stud
14	007-245-00	Drum Mounting Screw
15	007-116-00	Brake Mounting Bolt
16	006-017-00	Brake Mounting Nut
ns	005-008-00	Lockwasher

## Hub & Drum

Item	Part No.	Description
22	008-288-03	Oil Hub w/Cups and Studs
23	009-044-01	Drum - Machined
ns	009-044-03	Drum - for ABS
ns	008-288-05	Oil Hub and Drum w/Cups and Studs

## Hub & Rotor

Available on 13G – Not Offered on D90 or D100G

Item	Part No.	Description
22A	008-288-07	Oil Hub w/Cups and Studs
23A	070-006-01	Brake Rotor
28	006-046-00	Rotor Mounting Nut
29	025-014-00	Rotor Mounting Stud

ns - not shown

## 12 1/4" x 3 3/8" Brakes

Item	Part No.	Description
20	K23-450-00/K23-451-00	LH/RH Electric, FSA
21	K23-410-00/K23-411-00	LH/RH Hydraulic, FSA, Duo-Servo
21	K23-210-00/K23-211-00	LH/RH Hydraulic, FSA, Du-Servo w/Park
ns	K23-412-00/K23-413-00	LH/RH Hydraulic, FSA, Single-Servo
ns	K23-234-00/K23-235-00	LH/RH Hydraulic, Manual Adjust Single-Servo w/Park

## ABS Components

Item	Part No.	Description
24	097-004-00	Sensor, Straight
25	024-204-00	Sensor Block
26	097-002-00	Sensor Clip
27	024-203-00	Tone Ring

## Studs and Wheel Nuts

Item	Part No.	Description	Nut Torque
18*	006-109-00	5/8-18 90° Cone Nut	200 lbs.-ft
19*	033-052-01	Clamp Ring	
17	006-058-00	5/8-18 Flange Nut	300 lbs.-ft
13	007-115-00	5/8-18 Press-in Stud	

\* Must use the 90° cone nut with the clamp ring. Alternate fastener is just the flange nut.

One-piece hub/drum is not interchangeable with the two-piece hub & drum.