

Axle Types

1000-2200 Lbs. Capacity

- Complete service manual
- Heavy duty 1 1/8" spindle design
- Precision machined steel spindles and integral cast iron hub/drums
- CSA approved 7" x 1 1/4" electric and 7" x 1 3/4" hydraulic brakes
- Electric brakes are available with and without parking feature
- Standard grease lubrication; E-Z Lube® option
- Press-in wheel studs
- Inner wiring system for easier installation and protection of brake wiring



D20 LEAF SPRING



- Designed for light-capacity trailers
- Designed for travel trailers being towed by smaller automobiles
- High strength 1 3/4" diameter tube for straight axles and 2 3/8" for drops
- Straight or Drop spindles (4" drop only)
- High quality alloy steel springs in a variety of capacities
- Single, tandem, or triple axle assemblies with equalized suspensions
- Slipper spring or double eye leaf spring suspension
- Optional hanger and attaching parts kits available
- Durable, wear-resistant components
- 2 year limited warranty

- Designed for fold-down campers, light utility, boat trailer applications
- Totally rubber-cushioned for smooth, quiet, independent ride
- Easy installation with less maintenance
- Less transfer of road shock which insulates cargo from road shocks and vibration
- Rubber cords compounded for maximum dependability and durability
- Load-carrying cross member
- Self-damping action
- Independent wheel suspension system
- 5 year limited warranty on suspension system
- Low profile for maximum road clearance
- Various starting angles to control trailer height
- High and low profile brackets with optional mounting brackets available
- Rubber cushioning eliminates metal-to-metal contact
- Shock absorption provided by the natural hysteresis of rubber
- Single or tandem axle assemblies
- Durable, wear-resistant components

CAUTION: Triple axle assemblies are NOT recommended for Torflex® axles.



Articulation Dimensions

Dimensions are for top mount only. Side mount is .18" higher. Allow 3" bump clearance from full load.

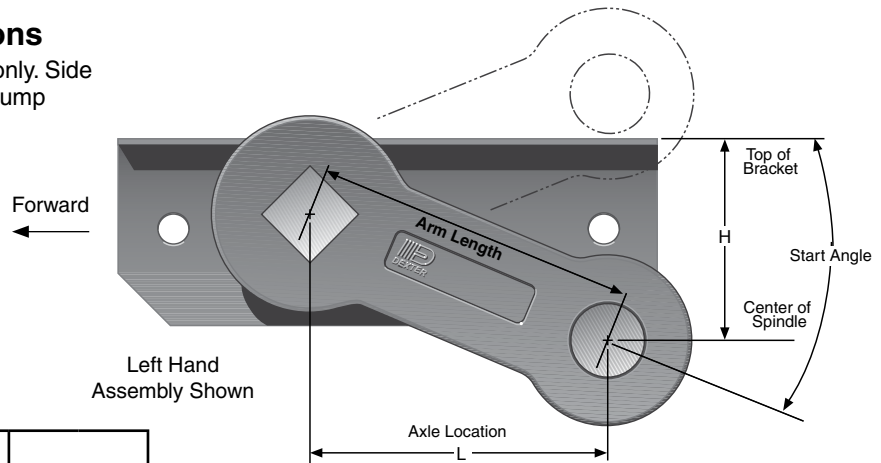

Start Angle	Bracket Profile	No Load		Full Load		Shock Load	
		H	L	H	L	H	L
45° Down	Low	5.46	4.24	3.52	5.54	2.52	5.86
	High	6.33	4.24	4.38	5.54	3.38	5.86
22.5° Down	Low	3.52	5.54	1.22	6.00	0.18	5.91
	High	4.38	5.54	2.00	6.00	1.04	5.91
10° Down	Low	2.26	5.91	-0.08	5.86	-1.08	5.54
	High	3.13	5.91	0.79	5.86	-0.21	5.54
0°	Low	1.22	6.00	-1.08	5.54	-2.00	5.06
	High	2.09	6.00	-0.21	5.54	-1.14	5.06
10° Up	Low	0.18	5.91	-2.00	5.06	-2.83	4.42
	High	1.04	5.91	-1.14	5.06	-1.97	4.42
22.5° Up	Low	-1.08	5.54	-3.02	4.24	-3.70	3.44
	High	-0.21	5.54	-2.16	4.24	-2.83	3.44

#9 Overhang Per Side

Spindle	Min.	Max.
Short	6.00"	10.90"
Standard	6.50"	10.90"

Note: Positive numbers in the H column indicate the spindle is BELOW the top of the bracket. Conversely, negative numbers are ABOVE the top of the bracket.



Full Load Dimensions

Dimensions are for low profile, top mount only. High profile brackets are .88" higher. Side mount is .18" higher. Allow 3" bump clearance from full load.

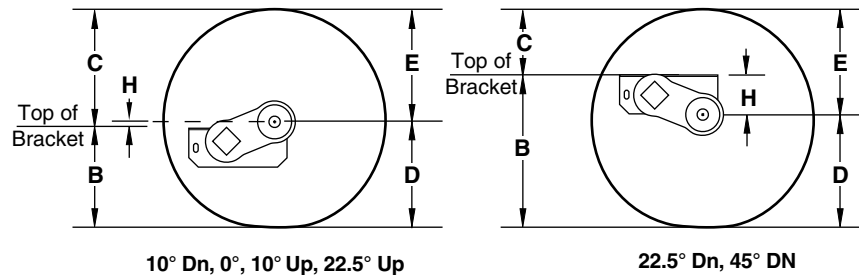

Start Angle

Tire	* D	** E	45° Down			22.5° Down			10° Down			0°			10° Up			22.5° Up		
			H	B	C	H	B	C	H	B	C	H	B	C	H	B	C			
ST175/80R13	11.2	12.0	3.5	14.7	8.5	1.2	12.4	10.8	-0.1	11.1	12.1	-1.1	10.1	13.1	-2.0	9.2	14.0	-3.0	8.2	15.0
4.80-8	7.9	8.8	3.5	11.4	5.3	1.2	9.1	7.6	-0.1	7.8	8.9	-1.1	6.8	9.9	-2.0	5.9	10.8	-3.0	4.9	11.8
4.80-12	9.5	10.8	3.5	13.0	7.3	1.2	10.7	9.6	-0.1	9.4	10.9	-1.1	8.4	11.9	-2.0	7.5	12.8	-3.0	6.5	13.8
20.5 x 8.0-10	9.7	10.8	3.5	13.2	7.3	1.2	10.9	9.6	-0.1	9.6	10.9	-1.1	8.6	11.9	-2.0	7.7	12.8	-3.0	6.7	13.8

Columns D and E are dimensional examples only:

* D – Static Loaded Radius

** E – Inflated Radius



9 Bracket Dimensions

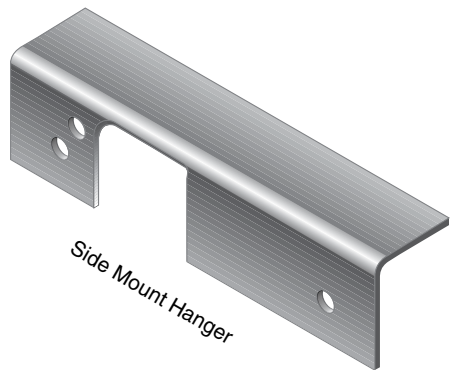
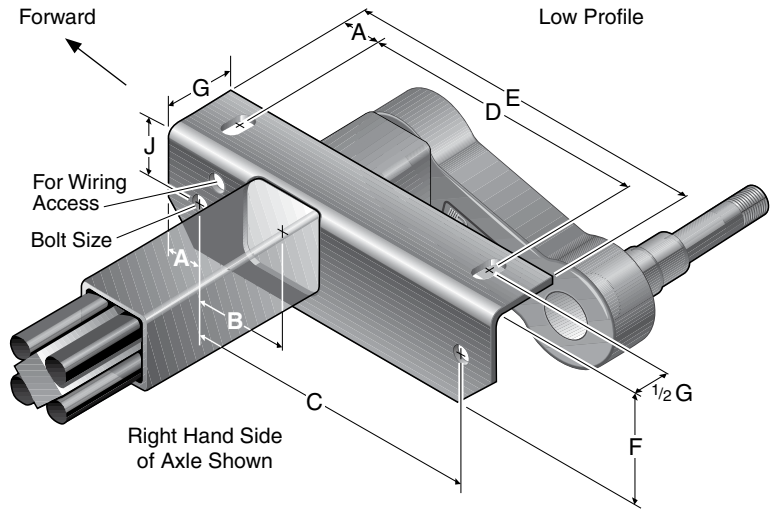

#9 Bracket Dimensions		
	Low	High
A	1.00	1.00
B	2.38	2.38
C	8.00	8.00
D	7.75	7.75
E	10.00	10.00
F	2.88	3.75
G	2.00	2.00
J	1.57	1.57
N	----	.86
P	----	.94
Q	----	1.00
Bolt Size	1/2" bolt	
Tube Size	2.17	2.17

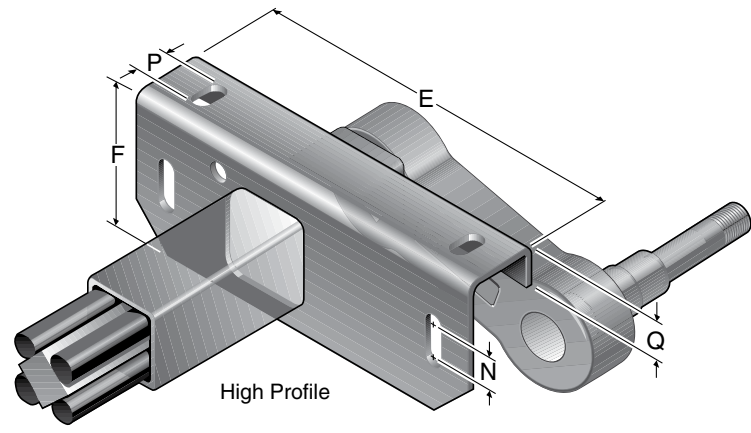

Leaf Spring Application Information



Double Eye Springs

For Standard 33" Axle Spacing
 Single A/P-122-00
 Tandem A/P-233-00
 Triple A/P-335-00

	Spring Length		
	21"	24"	26"
A	19.62	23.50	25.75
B	25.00	27.50	29.50
C	28.75	31.00	33.00
D	10.62	12.00	13.00
E	28.75	31.00	33.00

For Optional 35" Axle Spacing
 Tandem A/P-264-00
 Triple A/P-364-00

	Spring Length		
	21"	24"	26"
B	26.00	28.50	30.50
C	30.80	33.00	35.00
D	10.62	12.00	13.00
E	30.80	33.00	35.00

D20 Overhang Per Side

	Min.	Max.
Straight	5.75"	7.62"
Drop	7.62"	9.00"

A, B, E – Hanger Spacing
 C – Axle Spacing
 D – Axle Location
 H – Center of Spindle
 Y – Frame Height
 Z – Top of Tire to Bottom of Frame
 SLR – Static Load Radius

To determine these values, contact your local sales engineer or distributor to run ProSpec™.

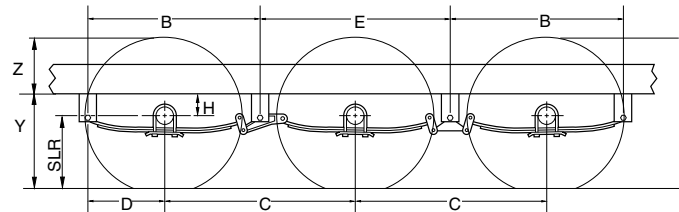
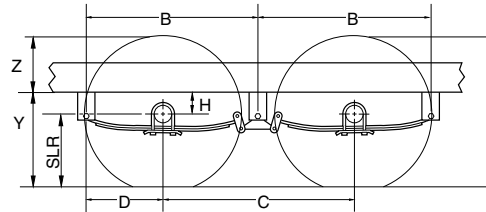
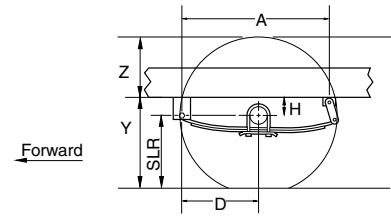

Double Eye Axle Assemblies

Hanger Kits

Part No.	Description	Height	Quantity Per Kit				
			HGR-104-00	HGR-105-00	HGR-248-00	HGR-249-00	HGR-348-00
028-005-00	Hanger	3.25"	2	---	4	2	4
028-006-00	Front Hanger	1.44"	---	2	---	---	---
029-008-00	Front Hanger	2.06"	---	---	---	4	---
029-031-00	Center Hanger	3.62"	---	---	2	---	4
030-020-00	Rear Hanger	.91"	2	2	---	---	---

Attaching Parts Kits

Part No.	Description	A/P-122-00	A/P-233-00	A/P-264-00†	A/P-335-00	A/P-364-00†
006-092-01	Flange Locknut	6	14	14	22	22
007-126-00	Shackle Bolt	2	6	6	10	10
013-104-02	Equalizer	---	2	---	2	---
013-105-02	Equalizer	---	---	---	2	---
013-122-02	Equalizer	---	---	2	---	2
013-126-02	Equalizer	---	---	---	---	2
018-011-00	Shackle Link	---	4	4	6	6
018-012-00	Shackle Link, Long	2	---	---	---	---
018-020-00	Shackle Link Assembly	---	4	4	6	6
018-021-00	Shackle Link Assembly, Long	2	---	---	---	---

† For 35" axle spacing using 26" springs

Slipper Spring Axle Assemblies

Hanger Kits

Part No.	Description	Ht.	HGR-115-00
028-039-00	Front Hanger	3.25"	2
030-037-00	Rear Hanger	1.44"	2

Attaching Parts Kits

Part No.	Description	A/P-115-00
006-092-01	Locknut	2
007-126-00	Shackle Bolt	2

Some combinations of hangers and spring mountings may result in insufficient bump clearance. Refer to the Miscellaneous section for additional hanger kits, A/P kits, or other tires.

Slipper Springs A/P-115-00

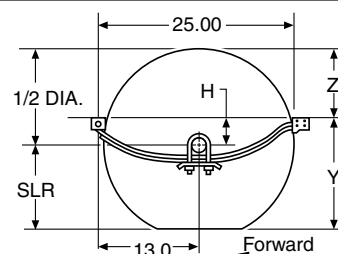

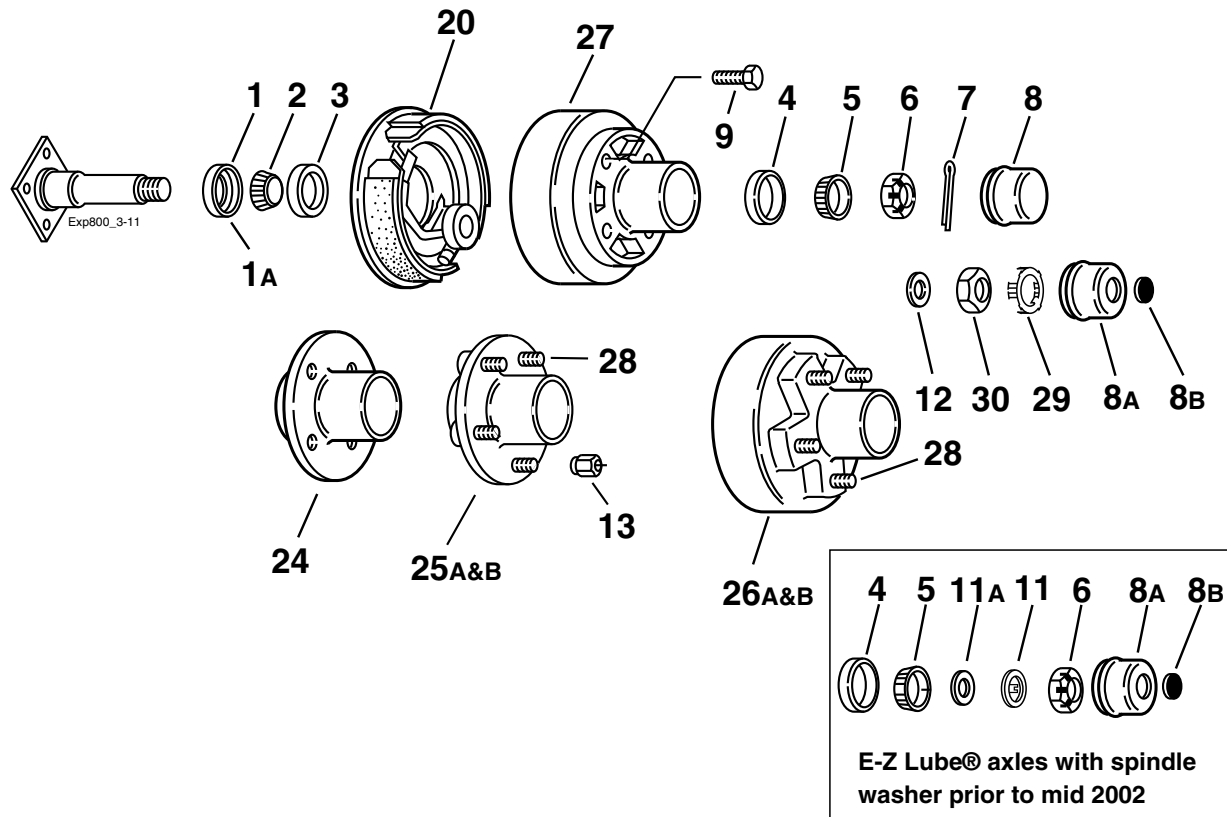

Grease Lube Parts

Item	Part No.	Description
1	010-009-00	Grease Seal
1A	010-060-00	Grease Seal for E-Z Lube®
2	031-031-02	L44649 Inner Bearing Cone
3	031-031-01	L44610 Inner Bearing Cup
4	031-031-01	L44610 Outer Bearing Cup
5	031-031-02	L44649 Outer Bearing Cone
6	006-176-00	Spindle Nut
7	019-002-00	Cotter Pin (not used with E-Z Lube®)
8	021-003-00	Grease Cap
8A	021-041-01	Grease Cap for E-Z Lube®
8B	085-001-00	Rubber Plug for E-Z Lube®
9	007-040-00	Wheel Bolt
11	005-101-00	Tang Washer for E-Z Lube® (before 2002)
11A	005-151-00	Spindle Washer for E-Z Lube® (before 2002)
12	005-023-00	Spindle Washer for E-Z Lube® (after 2002)
29	006-190-00	Spindle Nut Retainer for E-Z Lube® (after 2002)
30	006-191-00	Special Jam Nut for E-Z Lube® (after 2002)

Brakes

Item	Part No.	Description
20	K23-047-00/K23-048-00	LH/RH 7"x1 1/4" Electric
ns	K23-103-00/K23-104-00	LH/RH 7"x1 1/4" Electric w/park
ns	K23-398-00/K23-399-00	LH/RH 7"x1 1/4" Hydraulic Uni-servo

ns - not shown

Note: Spindle is not available for resale.

Hubs

Item	Part No.	Description	Bolt Circle
Hubs and Drums			
ns	008-173-16	1/2" Studs, elec. brakes ONLY	4 on 4.00
ns	008-276-05	1/2" Studs, hyd. brakes ONLY	4 on 4.00
26A	008-257-05	1/2" Studs, elec. brakes ONLY	5 on 4.50
26B	008-271-07	1/2" Studs, hyd. brakes ONLY	5 on 4.50
27	008-173-15	1/2" Tapped, elec. brakes ONLY	4 on 4.00
ns	008-257-04	1/2" Tapped, elec. brakes ONLY	5 on 4.50
ns	008-271-04	1/2" Tapped, hyd. brakes ONLY	5 on 4.50
Plain Hubs			
ns	008-091-05	1/2" Studs	4 on 4.00
24	008-091-04	1/2" Tapped	4 on 4.00
25A	008-259-05	1/2" Studs, 8"-12" wheels ONLY	5 on 4.50
25B	008-258-05	1/2" Studs, 13"-15" wheels ONLY	5 on 4.50
ns	008-259-04	1/2" Tapped, 8"-12" wheels ONLY	5 on 4.50
ns	008-258-04	1/2" Tapped, 13"-15" wheels ONLY	5 on 4.50

Studs & Wheel Nuts

Item	Part No.	Description
9	007-040-00	1/2-20 Wheel Bolt
13	006-080-00	1/2-20 60° Cone Nut
28	007-246-00	1/2-20 Press-in Stud

7" x 1¼" Electric Brake



CSA approved at 2000#/11.3 SLR; 2200#/10.2 SLR

1000 - 2200 LBS. CAPACITY

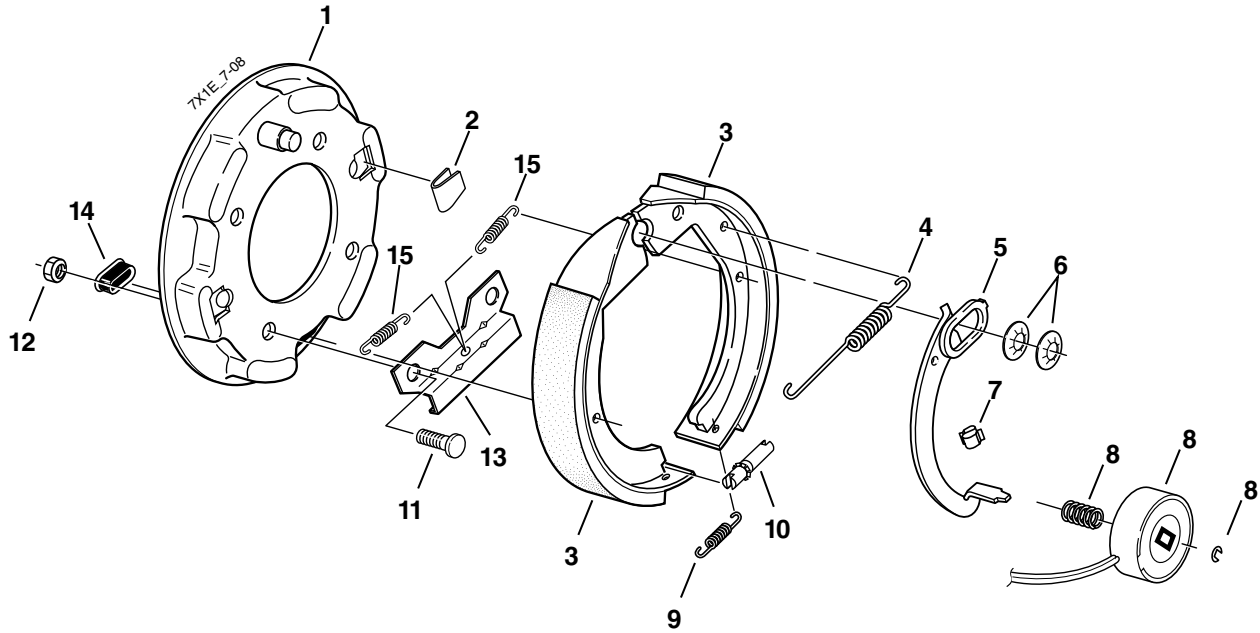

Electric Brake

Item	Part No.	Qty/Brk	Description
0	K23-047-00	1	LH Complete Brake Assembly (shown)
0	K23-048-00	1	RH Complete Brake Assembly
1	036-036-04	1	Backing Plate Assembly (includes items #11, 13)
2	046-023-00	2	Shoe Hold Down Clip
3	K71-045-00	1	Shoe & Lining Kit Contains: 1 #040-125-00 Primary Shoe & Lining 2 #040-049-00 Secondary Shoe & Lining
4	046-024-00	1	Retractor spring
5	047-114-03	1	LH Actuating Lever Arm
5	047-115-03	1	RH Actuating Lever Arm
6	046-030-00	2	Anchor Post Clip
7	027-005-00	1	Wire Clip
For brakes manufactured after 4/1/90			
8	K71-057-00	1	Magnet Kit Contains: 1 #040-134-00 Magnet 1 #046-121-00 Magnet Clip 1 #046-086-00 Magnet Spring
9	046-022-00	1	Adjusting Screw Spring
10	043-021-00	1	Adjusting Screw
11	007-041-00	4	Brake Mounting Bolt - Press-in
*12	006-017-00	4	Brake Mounting Nut
13	064-001-00	1	Stabilizer Bracket
14	046-007-00	1	Adjuster Slot Plug
For brakes manufactured after 8/1/91			
15	046-114-00	2	Shoe Centering Spring

* Not included with complete brake assembly. Item sold separately.

This brake is rated to a maximum capacity of 2200 lbs. / pair

7" x 1¼" Electric Brake With Parking Feature



CSA approved at 2000#/11.3 SLR; 2200#/10.2 SLR

1000 - 2200 LBS. CAPACITY

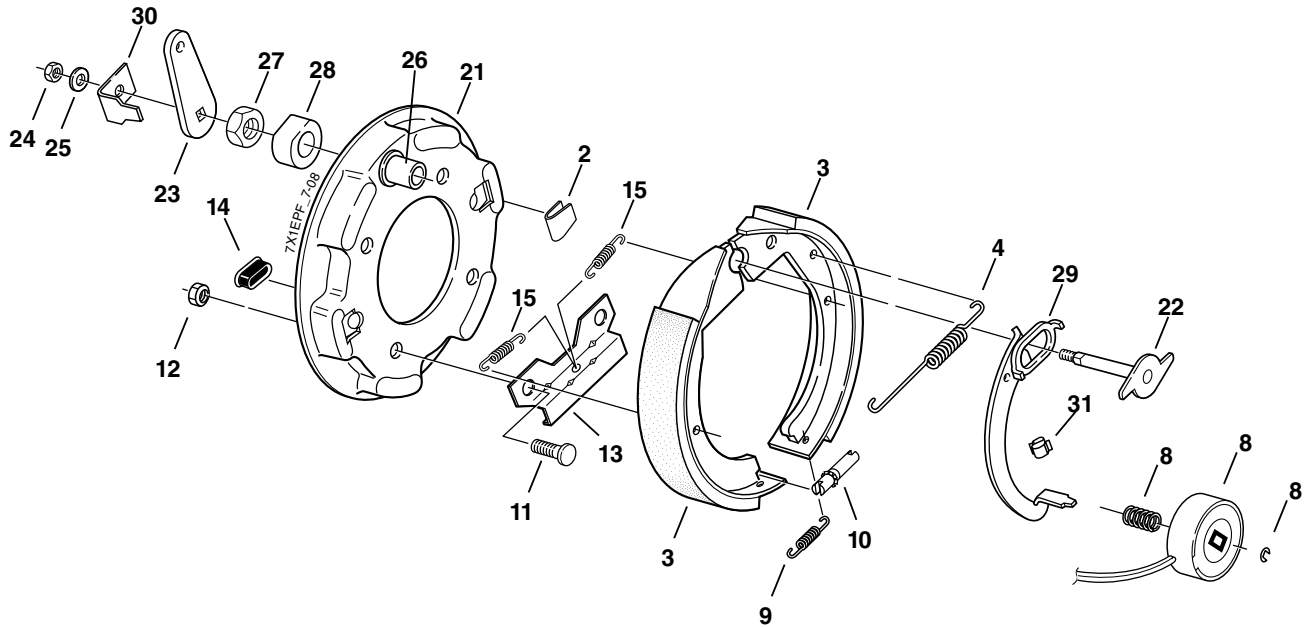

Electric Parking Brake

Item	Part No.	Qty/Brk	Description
0	K23-103-00	1	LH Complete Brake Assembly (shown)
0	K23-104-00	1	RH Complete Brake Assembly
2	046-023-00	2	Shoe Hold Down Clip
3	K71-045-00	1	Shoe & Lining Kit Contains: 1 #040-125-00 Primary Shoe & Lining 2 #040-049-00 Secondary Shoe & Lining
4	046-024-00	1	Retractor spring
For brakes manufactured after 4/1/90			
8	K71-057-00	1	Magnet Kit Contains: 1 #042-134-00 Magnet 1 #046-121-00 Magnet Clip 1 #046-086-00 Magnet Spring
9	046-022-00	1	Adjusting Screw Spring
10	043-021-00	1	Adjusting Screw
11	007-041-00	4	Brake Mounting Bolt - Press-in
*12	006-017-00	4	Brake Mounting Nut
13	064-001-00	1	Stabilizer Bracket
14	046-007-00	1	Adjuster Slot Plug
For brakes manufactured after 8/1/91			
15	046-114-00	2	Shoe Centering Spring

* Not included with complete brake assembly. Item sold separately.

Electric Parking Brake

Item	Part No.	Qty/Brk	Description
21	036-036-07	1	LH Backing Plate & Lever Arm (includes items #22-30, 2, 11, 13)
21	036-036-08	1	RH Backing Plate & Lever Arm (includes items #22-30, 2, 11, 13)
22	039-041-00	1	LH Pivot Pin & Cam Sub-Assembly
22	039-042-00	1	RH Pivot Pin & Cam Sub-Assembly
23	047-079-00	1	Lever
24	006-075-00	1	Self Locking Nut
25	005-056-00	1	Washer
26	038-057-00	1	Anchor Pin
27	006-074-00	1	Self Locking Nut
28	071-031-00	1	Spacer
29	047-114-02	1	LH Lever Arm & Cam Assembly
29	047-115-02	1	RH Lever Arm & Cam Assembly
30	071-033-00	1	Lever Stop
31	027-005-00	1	Wire Clip

This brake is rated to a maximum capacity of 2200 lbs. / pair

7" x 1³/₄" Hydraulic Brake



CSA approved at 2500#/11.2 SLR

1000 - 2200 LBS. CAPACITY

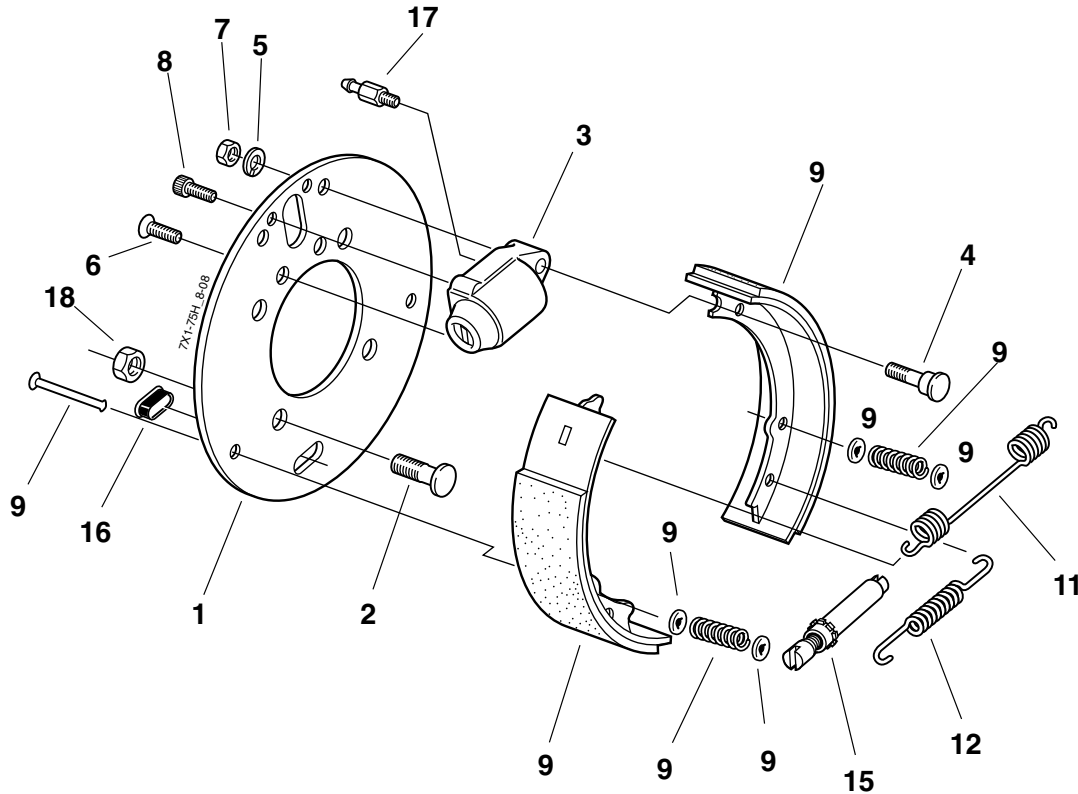

Hydraulic Brake

Item	Part No.	Qty/Brk	Description
0	K23-398-00	1	LH Complete Brake Assembly (shown)
0	K23-399-00	1	RH Complete Brake Assembly
1	036-038-00	1	Backing Plate
2	007-041-00	4	Brake Mounting Bolt - Press-in
3	054-080-03	1	Wheel Cylinder Assembly - LH (includes item #17)
3	054-080-04	1	Wheel Cylinder Assembly - RH (includes item #17)
4	038-072-00	1	Anchor Post
5	005-004-00	1	Lock Washer
6	007-235-00	1	Counter Sunk Cap Screw
7	006-010-00	1	Hex Nut
8	007-234-00	1	Socket Head Cap Screw
9	K71-466-00	1	Shoe & Lining Kit Contains:
			1 #040-327-01 Primary Shoe & Lining
			1 #040-328-01 Secondary Shoe & Lining
			2 #046-006-00 Shoe Hold Down Spring
			4 #035-001-00 Shoe Hold Down Spring Cup
			2 #049-014-00 Shoe Hold Down Pin
11	046-126-00	1	Retractor spring
12	046-127-00	1	Adjusting Screw Spring
15	043-004-00	1	Adjuster Screw Assembly
16	046-007-00	1	Adjuster Slot Plug
17	054-084-00	1	Bleeder Screw 6mm Thread (brakes before 1/97)
17	054-088-00	1	Bleeder Screw 7mm Thread (brakes after 1/97)
*18	006-017-00	4	Brake Mounting Nut

* Not included with complete brake assembly. Item sold separately.

This brake is rated to a maximum capacity of 2200 lbs. / pair