

<THESE INSTRUCTIONS MUST BE GIVEN TO THE END USER>



B&W Trailer Hitches

1216 HWY 224 / PO Box 186

Humboldt, KS 66748

P: 620.473.3664

F: 620.473.3766

Call or Email us for

Installation Support

hitches@turnoverball.com

www.turnoverball.com

Turnoverball™ Gooseneck Hitch Installation Instructions

MODEL 1314

2013 Dodge 3500 1 Ton Long & Short bed Trucks.

HITCH ASSEMBLY PARTS LIST		
ITEM	DISCRIPTION	QTY
1	Center Section	1
2	Threaded Block Driver	1
3	Threaded Block Passenger	1
4	Latch Pin Handle	1
5	Plastic Spacer Block	1
6	1/2" x 2-3/4" x 4-5/16" U-Bolt	2
7	2-5/16" Ball	1
8	Conical Spring	4
9	1/2" Center Lock Nut	4
10	Hole Template	1

HARDWARE KIT		
DESCRIPTION	QTY	
5/8" X 1-1/2" Locking Cap Screw	6	
3/8" X 1" Carriage Bolt	2	
3/8" Center Lock Nut	2	

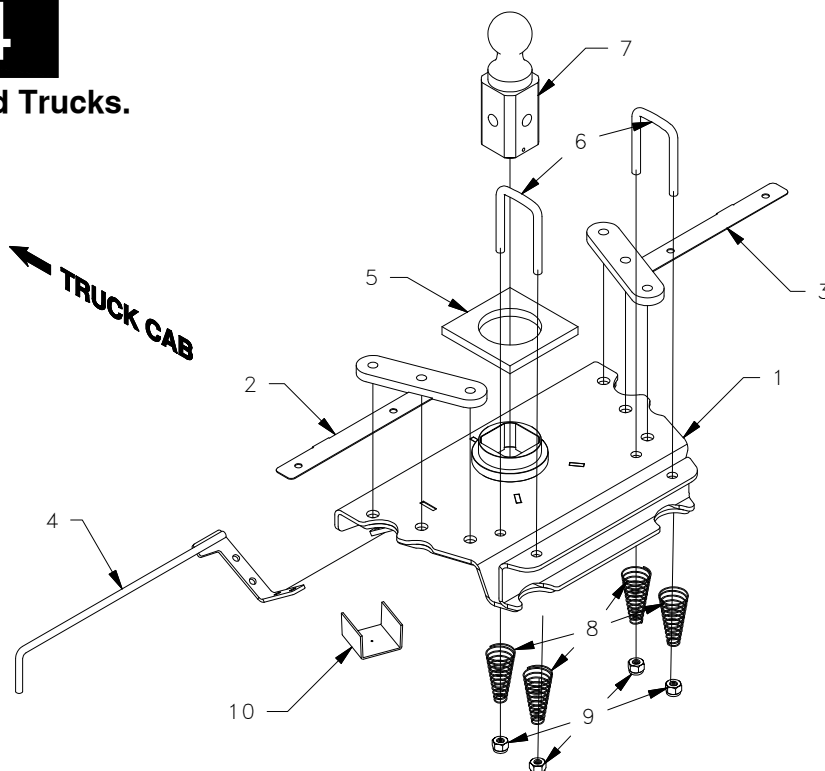

⚠ WARNING

Failure to comply with the safety information in these instructions could result in serious injury or death.

- ⚠ Read all installation and operating instructions along with all labels before using this product.
- ⚠ Without proper knowledge, towing can be a dangerous activity. Understand all the risks involved with towing before proceeding. For information on towing safety, see **"The Trailer Handbook: A guide to Understanding Trailer and Towing Safety"** from the National Association of Trailer Manufacturers, www.NATM.com.
- ⚠ The Turnoverball hitch comes equipped with a 2-5/16" ball. Trailers towed with the ball provided must have a 2-5/16" coupler. Towing with a larger coupler could cause loss of attachment between the trailer and the tow vehicle.
- ⚠ Do not modify this product in any manner. Doing so could alter its integrity and lead to a loss of attachment between the trailer and the tow vehicle.
- ⚠ Do not exceed tow or tongue rating of coupler, tow or tongue rating of hitch, or tow or weight ratings of truck or trailer. See vehicle and trailer manufacturer information for ratings. Exceeding these ratings may cause damage to towing components or loss of attachment between the trailer and truck.
- ⚠ Adding components such as a Turnoverball hitch to the chassis of any vehicle can be hazardous. There is potential for unexpected combustion of fuel, electric shock, burns, shifting or falling of unstable vehicle, damage to vehicle, injury from tool usage and many other hazards. This installation must be completed by someone who is aware of the hazards involved. This person must be knowledgeable of proper safety procedures for a vehicle modification of this nature, and for usage of the equipment required to perform the installation.

PREPARING TO INSTALL

NOTE: Remove all parts from the packaging and familiarize yourself with all the parts and tools required. Use the parts list on the front page to verify that all parts and hardware are present.

TOOLS REQUIRED

- Impact wrench or ratchet with 10mm, 9/16", 3/4" & 15/16" sockets.
- Marking tool (pencil or permanent marker)
- 3-1/2" hole saw
- Drill with 1/2" & 1/4" bits
- Ear protection
- Lifting device
- Tape measure
- Pry Bar
- Flashlight
- Eye protection
- Torque wrench
- Center punch
- Soap and water

1. **Determine cab clearance:** Under the truck bed, measure from the rear most edge of the C-channel frame crossmember (over the axle) to the end of the bed, see figure A1, Length A. Next, inside the bed, measure the length of the bed from the rear edge to the front, see figure A1, Length B. Subtract the crossmember measurement (length A) from the bed measurement (Length B). Then subtract an additional 6 inches. This will give you the amount of clearance you have between the turnoverball location and the cab. Measure the distance from the center of the coupler to the farthest forward corner point of the trailer. Compare this distance to the measurement from the center of the ball to the cab. These measurements will allow you to see how much clearance you will have between the cab and the trailer while towing and turning, see figure A2.

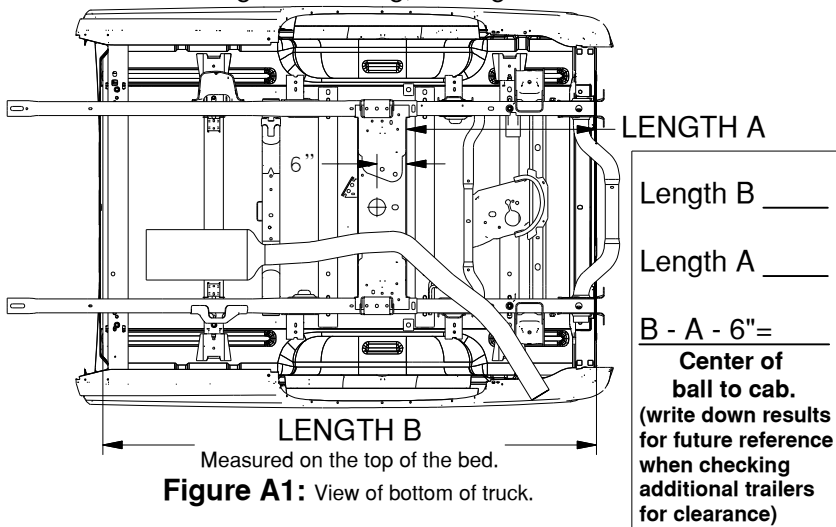

Figure A1: View of bottom of truck.

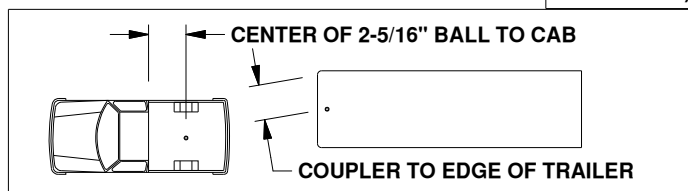

Figure A2: Truck and trailer diagram

⚠ Cab clearance on short bed trucks is very limited when towing certain trailers. Failure to insure that there will be adequate clearance, may result in significant property damage, or serious injury.

2. **Remove the spare tire (optional).** Following the vehicle manufacturer's instructions, remove the spare tire. This will provide easier access to the area where the hitch will be installed.
3. **Remove the heatsheild (optional):** Remove the bolts connecting the heatshield to the frame and set the heat shield aside for later installation.
4. **Position the vehicle.** Installation of the hitch requires the installer to be under the truck bed in the area of the rear axle. Lifting the vehicle makes this area more accessible to the installer, and improves the installation process.

⚠ Lift vehicle using only equipment designed for lifting and positioning vehicles for service. Failure to do so may result in property damage, serious injury, or death.

5. **Prepare a lifting device (optional).** The purpose of the device is to safely hold the hitch in position during part of the installation. See figure A3 for an example. A simple mechanical lifting device is available for purchase from B&W.

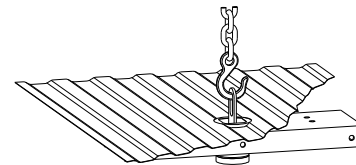

Figure A3

6. **Remove or modify fender liners as needed.** Some vehicles are equipped with various designs of plastic liners inside the rear wheel wells. If the liner in the driver side wheel well prevents access to the opening between the bed and the frame, just over the axle, it may need to be removed or cut to install the handle.
7. **Disconnect the exhaust hanger:** Locate the exhaust hanger in the rear passenger portion of the truck, see figure A4. Disconnect the exhaust from the hanger to provide improved mounting access to the center section. It is recommended to use a pry bar to aid in disconnecting the exhaust hanger, as shown in figure A4.

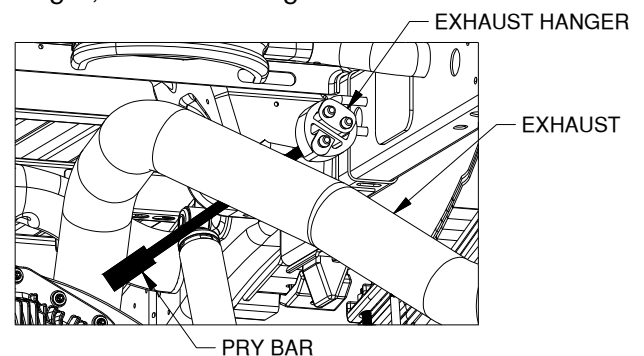

Figure A4: Looking under truck bed towards cab

8. **Mark the location of the 3-1/2" hole.** Insert the hole template into the center hole of the frame cross member as shown in figure A4. Push the template upward until it is flush against the bottom of the bed floor. Make a mark on the truck bed floor through the hole in the hole template using a pencil, marker, or other tool. Once the center point is marked, remove the template. Use a center punch to place an indentation in the truck bed at the center of the mark. Using a drill and a 1/4" bit, drill a pilot hole through the bed in this location.

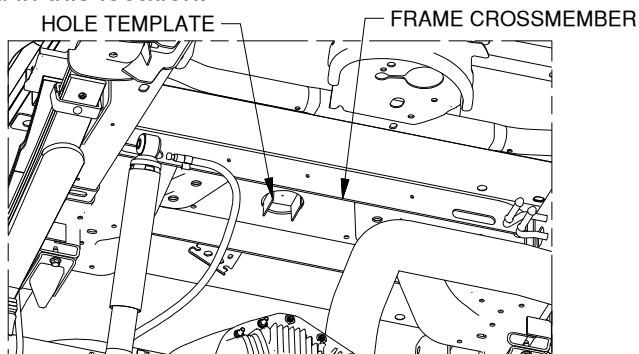

Figure A4: View under bed looking towards the cab.

9. **Cut the 3-1/2" diameter hole.** From the top side of the bed, use the pilot hole and a hole saw to create a 3-1/2" diameter hole in the truck bed floor. A saber saw equipped with a metal cutting blade may also be used if the 3-1/2" diameter circle is laid out on the bed floor around the center of the pilot hole. Remove any burrs created while cutting the hole. The size of the round portion of the hitch that will be seen from the truck bed is determined by the size of the hole in the truck's frame. The closest nominal hole size to this feature is 3-1/2". The 3-1/2" hole will leave a gap around the hitch structure. This gap will be filled in by the plastic spacer block.

INSTALL CENTER SECTION

- ⚠ Most trucks have fuel lines, brake lines, electrical wires or other vehicle systems located along the frame rails or in the general area where B&W Turnoverball hitches install. Carefully examine the locations of these systems before installation. Make certain that these are not damaged during positioning hitch components, drilling holes, or tightening fasteners. Damage to these systems may result in property damage, serious injury, or death.**

- ⚠ Turnoverball hitch components are heavy and may be cumbersome to handle. Failure to use proper lifting techniques and caution when handling these items could result in serious injury.**

1. **Place spacer block.** Position the plastic spacer block between the frame cross member and the bed as shown. See figure B1. Center the hole in the spacer block over the hole in the frame.

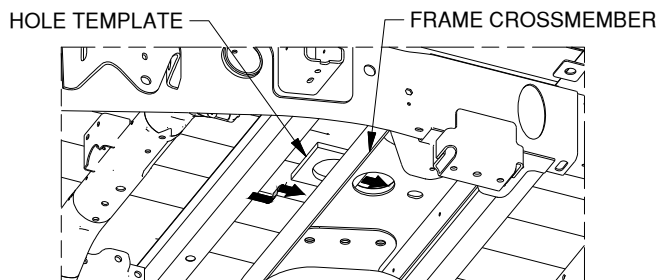

Figure B1: Looking up at bed from forward of driver side tire.

2. **Install threaded blocks.** Identify the driver and passenger side threaded blocks by comparing the parts to figure B2. Place the threaded blocks between the frame cross member and the bed on their respective sides, see figure B3. Use the handle welded to the blocks to guide them into place. Once the blocks are positioned, lower the handle so that the tab on the bottom side of the handle fits into the hole as shown in figure B4. This will help hold the blocks into position while the center section is installed. Make sure that the three threaded holes in the blocks are directly over the holes in the frame.

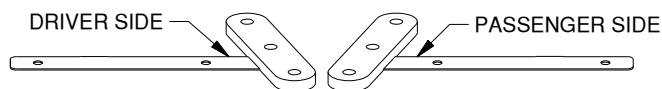

Figure B2: Threaded Blocks

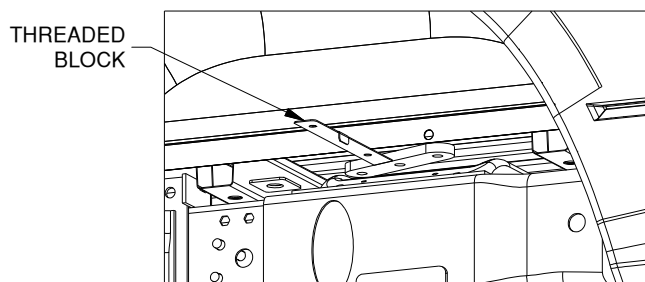

Figure B3: Looking at driver side wheel well.

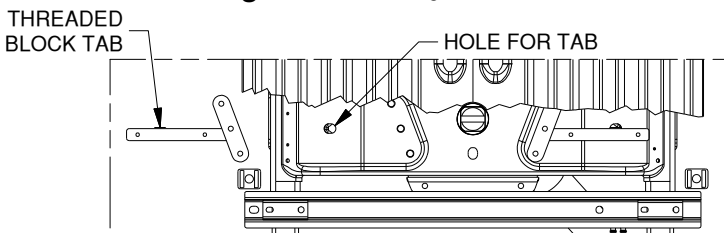

Figure B4: Cutaway view looking down into bed.

- 3. Install the center section.** With the latch pin mechanism on the driver's side, raise the center section into place as shown, see figure B4. In order to clear structures under the truck bed, the center will have to be lifted into place on an angle over the exhaust, then positioned directly under the frame cross member so that the raised portion of the center can be pushed straight up through the hole in the frame cross member, and through the hole in the plastic spacer block. Having assistance in the bed to guide the top of the center section is recommended. Line the 6 holes in the center section up with the frame holes and the holes in the threaded blocks. Thread a 5/8 flange head bolt into each hole. Next, Run the bolts in until they are about 1/16" from being tight.

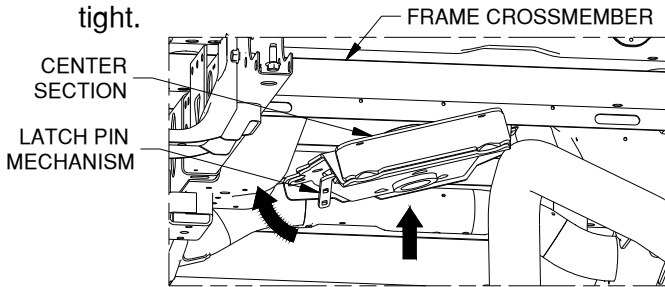

Figure B4: Looking from rear towards cab.

SECURE HITCH

- 1. Square the hitch.** Using a tape measure, be sure that the full length of the gooseneck hitch is centered within the channel of the frame cross member. Do this by making sure that the gap between the center section and the frame cross member is the same on the driver and passenger sides. The hitch must not be touching the brake lines that are anchored to the frame cross member.
- 2. Tighten the bolts.** With the hitch square and firmly pressed against the frame cross member, tighten the 5/8" bolts. Tighten the center bolt of each three-bolt pattern first, see figure C1. Then tighten the rest, see figure C2. To better access the bolts on the passenger side of the center section move the exhaust as needed to allow access to the bolts. Torque the bolts to 100 ft. lbs.

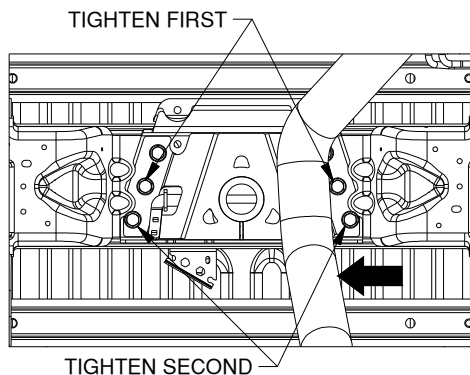

Figure C1: View under bed looking at center
(Exhaust pushed toward inside.)

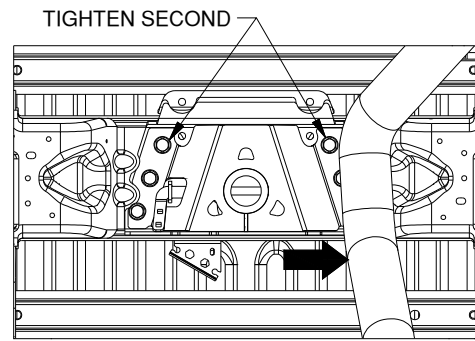

Figure C2: View under bed looking at center.
(Exhaust pushed toward outside)

- 3. Disengage lifting device.** If a lifting device was used to hold the center section in place during the installation, remove it at this time.

INSTALL LATCH PIN HANDLE

- 1. Install bolts.** Retract the latching mechanism by pulling on the tab with the square holes and pushing it toward the cab. Insert a 3/8 carriage bolt in each of the square holes in the latching mechanism. Retract the latching mechanism by pushing the tab with the square hole toward the rear of the truck, see figure D1.

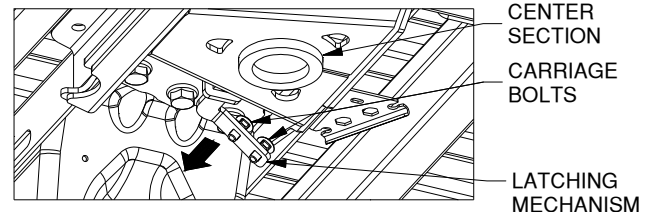

Figure D1: Looking up at center section.

⚠ Serious injury can occur due to the pinch point located at the intersection of the latching mechanism and the center section.

- 2. Install the latch pin handle.** Beginning under the vehicle, "thread" the end of the handle, with the vinyl grip, in front of the brake lines and over the frame on the driver's side. Attach the handle to the latching mechanism over the 3/8 carriage bolts with two 3/8 locking flange nuts, see figure D2. Be sure that the handle is in the proper position and that it does not interfere with any other components of the vehicle. Torque the nuts to 30 ft. lbs. to secure the handle.

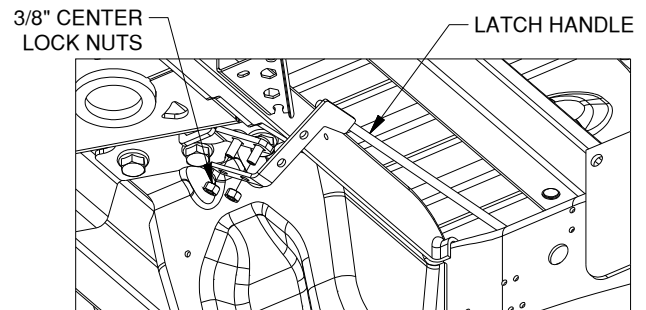

Figure D2: Looking back at driver side of center section.

Notice: the latch handle must be positioned on the "cab side" of the brake lines directly over the axle.

INSTALL SAFETY CHAIN U-BOLTS

This Turnoverball hitch is equipped with holes in the center section for mounting safety chain U-bolts.

1. **Drill the holes.** From under the bed, use a drill and a 1/2" drill bit to drill through the frame cross member and bed using the 9/16" holes in the center as a guide. Two of the holes will go through the frame cross member and the bed, and the other two will go through the bed only. Be sure to drill the holes perpendicular to the surface of the bed.
2. **Install the U-bolts.** From the top side of the truck bed, drop a U-bolt in each set of holes.
3. **Add springs.** Place a conical spring over each leg of the U-bolts and secure with a 1/2" lock nut, see figure E1. Tighten the lock nut until the nut is flush with the end of the U-bolt.

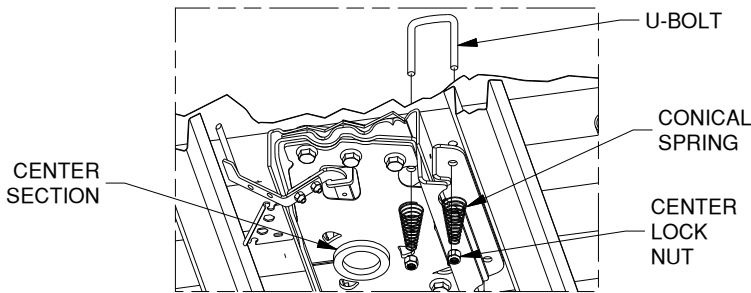

Figure E1: Cutaway, looking up at driver side of center section.

INSTALL FRAME STICKER

1. **Place handle sticker.** Locate the latch handle sticker provided with your instruction packet. Apply the sticker to the frame in the driver side wheel well. Align the left edge of the sticker with the latch handle and top and bottom edges of the sticker with the frame.

PREPARE FOR TOWING

1. **Replace spare tire and heat shield.** If the spare tire and/or the heat shield was removed prior to installing the hitch, replace it at this time.
2. **Re-attach Exhaust bracket.** Pull the exhaust back up to the exhaust bracket and re-attach. We recommend using soap and water to lubricate the "pin" and the rubber hanger which attach the exhaust hanger to aid in re-attachment.
3. **Modify fender liner.** If a fender liner is present that restricts the movement of the handle, it is recommended that it be modified by cutting a relief slot or hole to allow the handle to move freely. If the liner was removed for installation, reinstall at this time.
4. **Retract the pin.** Pull the handle out all the way until it stops then slide it toward the cab. The handle should stay in this position. The latch should only be put in this open position when inverting the 2-5/16" ball or installing a B&W towing accessory.

Warning: Operating the tow vehicle while the latch is in the open position may allow the handle to come into contact with the rear tire. This may damage the tire or the handle and could lead to serious injury or death.

5. **Lubricate 2-5/16" ball.** Apply a light coating of grease to the corners on the square shank of the 2-5/16" ball.
6. **Check latch pin engagement.** When installed properly, the latch pin mechanism should pass through both sides of the ball socket. With the ball removed, push handle toward the rear of the truck until the handle retracts and the latch pin engages. Visually inspect the ball socket and check to be sure the latch pin has passed completely through the socket. Make a mark on the latching mechanism where indicated in diagram G1 to indicate where the latching mechanism should be when the pin is correctly positioned in the ball socket. Retract the pin, replace the ball, and re-engage the pin. Check the marked location on the latching mechanism. If the mark is in the same location it was in when the mark was made then the latch pin has gone completely through the ball socket.

Warning: Failure of the pin to engage the ball and hitch properly could result in a loss of attachment between the trailer and the tow vehicle

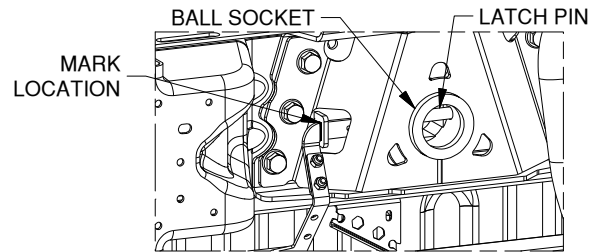

Figure G1: View of center section looking up under the bed.

OPERATION & MAINTENANCE

- Always be sure that latch pin is fully engaged in the socket before towing.
- Inspect hardware connections before towing to be sure that they are secure.
- Measure and determine turning clearance with cab before towing unfamiliar trailers. Additional products for increasing turning clearance are available from B&W.
- When inverting the ball, inspect the ball's relationship with the truck's differential and drive line to insure proper clearance. **DO NOT INVERT THE BALL WHEN HAULING HEAVY LOADS ON 2 WHEEL DRIVE TRUCKS.** A plug for the socket is available from B&W so that the ball may be removed and the socket may be covered when hauling heavy loads.
- Periodically grease the corners on the square shank of the 2-5/16" ball.